



# User Manual

PL-500AV-4PE

HomePlug 500 AV 4-Port Ethernet Bridge

# Safety

## FCC

This equipment has been tested and found to comply with Part 15 Class B of the FCC Rules. Operation is subject to the following two conditions:

- (1) This device may not cause harmful interference
- (2) This device must accept any interference received, including interference that may cause undesired operation.

## CE

This equipment is in compliance with the requirements of the following regulations: CE Mark, 89/336/EEC

## RoHS

This product is RoHS compliant.



# Table of Contents

1	<a href="#">HomePlug power line</a>	4
1.2	<a href="#">System Diagram</a>	4
1.3	<a href="#">Casing Details</a>	6
	Front Casing	6
	Status Lights	7
	Bottom Casing	8
	Left Casing and <a href="#">Buttons</a>	8
1.4	<a href="#">Initial Setup</a>	9
	Connect the HomePlug AV 4-Port Ethernet Bridge to a Computer or Modem/Router	9
2	<a href="#">Individual HomePlug AV Network Setup (Optional)</a>	11
2.1	<a href="#">Creating a new individual HomePlug AV network (Network AB)</a>	12
2.2	<a href="#">Adding Bridge C to existing Network AB (Network ABC)</a>	14
2.3	<a href="#">Removing Bridge B from Bridge A &amp; C Network and join with Bridge D &amp; E (Network BDE)</a>	16
3	<a href="#">Troubleshooting</a>	18
4	<a href="#">Specification</a>	10

## HomePlug power line

---

HomePlug power line is an excellent solution that can be used to extend your network. In the home or small office building, use HomePlug Ethernet Bridges to link multiple locations without the need to run long Ethernet cables. Combined with a broadband DSL/Cable connection, every room with electrical power outlets will have easy access to high-speed Internet connection. With the HomePlug AV speed of up to 500Mbps, this easy-to-setup solution can provide fast streaming HD movies, online multi-player games, and other data intensive activities for today's HD Entertainment Center demand.

### **Introduction**

Each HomePlug AV Ethernet Bridge allows you to connect one device that has an Ethernet port to a power line network. In operation, the HomePlug AV Ethernet Bridge is completely transparent, and simply passes data between the Ethernet port and the power line network. Any Ethernet-enabled device may be connected to the HomePlug AV Ethernet Bridge's Ethernet port.

## System Diagram

Add high-speed Internet access to any room in your home with this HomePlug AV Ethernet Bridge. You can stream HD movies and music, play online multi-player games and much more. The best part of this PS957-EB has built-in 4 ports so up to 4 network enabled devices nearby can be networked at the same time.

Note: This HomePlug AV 4-Port Ethernet Bridge needs to pair with at least one other HomePlug AV compatible device such as this one in order to create a working system.

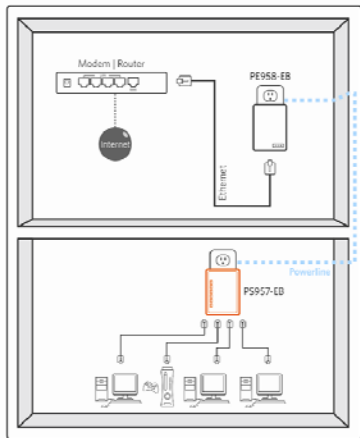

## Casing Details

### Front Casing

The front casing contains 3 types of status lights: Power, PLC Link, and Ethernet Link Port 1 ~ 4.

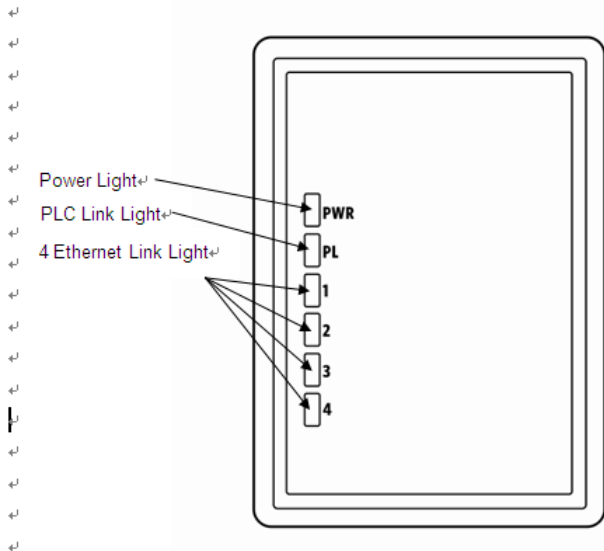

## Status Lights

### **Power**

On: This HomePlug Ethernet Bridge is receiving electrical power

Off: Power off

### **PLC Link**

The PLC (power line) Link light will indicate the overall speed of your network with 3 colors:

Red: Minimum connection indicates weak signal and slower network speed: less than 50Mbps

Orange: Normal signal with standard network speed: 50-100Mbps

Green: Excellent signal with optimal network speed: 100Mbps+

Off: No activity. This HomePlug Ethernet Bridge is not connected

### **Ethernet Link 1, 2, 3, 4**

Solid Green: 10/100/1000Mbps port linked

Blinking: 10/100/1000Mbps port transmitting or receiving

Off: Ethernet Link not active

## Left Casing and Buttons

The left casing contains a recessed Reset button, a Security button.

### Security

This button is designed to generate an individual HomePlug AV network group under multiple nodes environment. Please refer to the optional **Individual HomePlug AV Network Setup** section below for more details.

### Reset

This button is used to clear ALL data and restore ALL settings to the factory default values.

Note: The HomePlug AV Ethernet Bridge must be plugged in to restore it to factory defaults. Using a small object like a paper clip, depress and hold the Reset button until the status lights begin to flash. The Reset button will need to be depressed for about 10 to 15 seconds for the reset to occur.

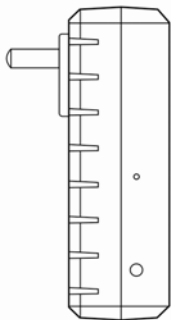



## Initial Setup

HomePlug is a plug and play device; user is able to plug and play without any complex configuration and settings. You can use HomePlug AV Ethernet Bridge to connect networkable devices like computers and game consoles directly to each other. You can also connect devices like a computer or Blu-ray Disc™ player to a router or modem for Internet access.

## **Connect the HomePlug AV 4-Port Ethernet Bridge to a Computer or Modem/Router**

Plug one end of the Ethernet Cable into the Ethernet Port on the bottom of the HomePlug AV Ethernet Bridge  
Plug the HomePlug AV Ethernet Bridge into a AC Wall Power Outlet near the device you want to connect

*Warning: Do not plug this HomePlug AV Ethernet Bridge into a powerstrip that has surge protection. Doing so will degrade power line performance. For best performance, plug all HomePlug AV Ethernet Bridges directly into a wall outlet.*

For connecting to a computer: Plug the other end of the Ethernet Cable into an OPEN Ethernet Port located on your computer.

For connecting to a Modem or Router for Internet access: Plug the other end of the Ethernet Cable into an OPEN Ethernet Port on your Modem or Router.

Make sure that the PLC Link light on each HomePlug AV Ethernet Bridge turns solid green.

Your HomePlug AV Ethernet Bridges are now connected forming a HomePlug AV network.

## Individual HomePlug AV Network Setup (Optional)

---

All HomePlug AV Ethernet Bridges ship with a default security key so they will automatically link to all other HomePlug AV Ethernet Bridges sharing the same electrical lines. If there are other HomePlug AV Ethernet Bridges in the building (such as in an office or apartment building), you may want to create your own individual HomePlug AV network group so other HomePlug AV Ethernet Bridges cannot connect to your network.

This section describes how to use the Security button for configuration in the following situations:

## Creating a new individual HomePlug AV network (Network AB)

Two unassociated Bridges (**Bridge A** and **Bridge B**) are forming a new network—Network AB

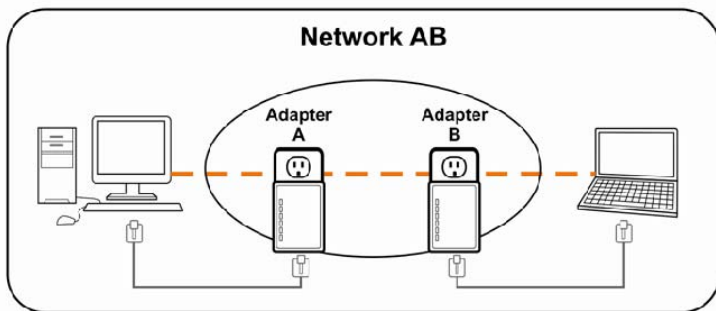

## The procedure is as follows:

1. Press and hold the Security button on *Bridge A* for 10 seconds. Release it when the Power light flashes. The password to *Bridge A* has just been erased. It must now be linked to your network to adopt the new network security key.
2. Press and hold the security button on *Bridge B* for 10 seconds and release it when the Power light flashes. The password to *Bridge B* has just been erased. It must now be linked to your network to adopt the new network security key.
3. Currently, *Bridge A* and *Bridge B* are not networked
4. Press and hold the Security button on *Bridge A* for 2 seconds then release.
5. The Power light on *Bridge A* starts to flash.
6. Within 120 seconds after the Power light on *Bridge A* starts to flash, press and hold the Security button on *Bridge B* for 2 seconds then release.
7. Both *Bridge A* and *Bridge B* are now networked together.

## Adding Bridge C to existing Network AB (Network ABC)

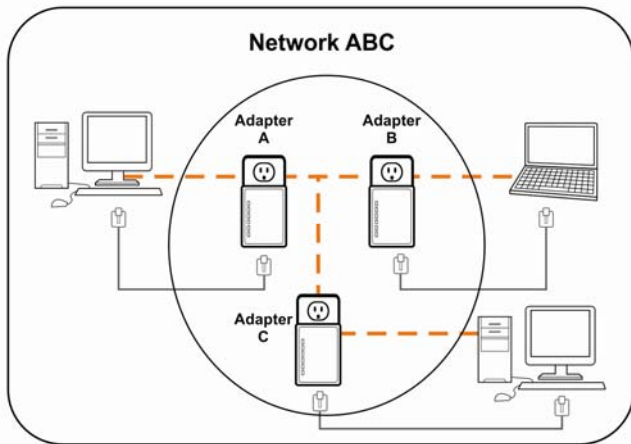

One unassociated **Bridge C** is added to an existing Network AB.

**The procedure is as follows:**

1. Press and hold the Security button on *Bridge C* for 10 seconds. Release it when the Power light flashes. The password to *Bridge C* has just been erased. It must now be linked to your network to adopt the new network security key.
2. Press and hold the security button on *Bridge A* for 2 seconds. The Power light on *Bridge A* starts to flash.
3. Within 120 seconds after the Power light on *Bridge A* starts to flash, press and hold the security button on *Bridge C* for 2 seconds then release.
4. *Bridge A*, *Bridge B* and *Bridge C* are now networked to each other.

# Removing Bridge B from Bridge A & C Network and join with Bridge D & E (Network BDE)

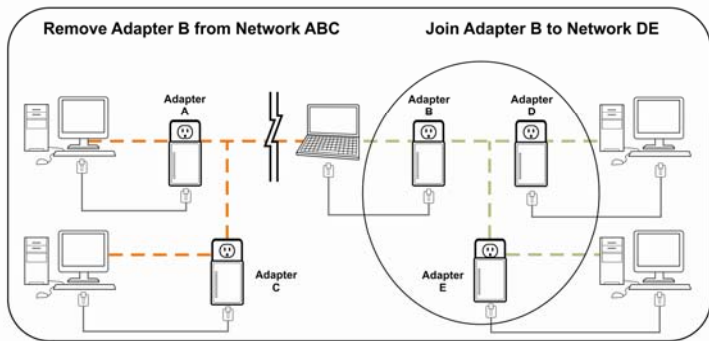



**The procedure is as follows:**

1. Press and hold the Security button on *Bridge B* for 10 seconds. Release it when the Power light flashes. The password to *Bridge B* has just been erased and removes itself from *Bridge A & C*.
2. Press and hold the Security button on *Bridge D* for 2 seconds.
3. Within 120 seconds after the Power light on *Bridge D* starts to flash, press and hold the Security button on *Bridge B* for 2 seconds then release.
4. *Bridge B* and *Bridge D* are now connected to each other, which in turn becomes part of Network BDE.

## Troubleshooting

---

- If your HomePlug AV Ethernet Bridges have difficulty communicating with each other, check the following:
- Try power cycling the unit by unplugging it from the wall for 10 seconds and plugging it in again.
- Use a pin and hold the Reset button down for 2 seconds on each unit you are trying to connect. The HomePlug AV Ethernet Bridge's light will flash, the units will reset and attempt to link using default factory settings.
- Try plugging the HomePlug AV Ethernet Bridge into an adjacent plug.
- HomePlug AV Ethernet Bridges work better when plugged directly into the wall outlet. Connecting these Ethernet Bridges to a power strip or surge protector may degrade network performance or completely stop network signals.
- This HomePlug AV Ethernet Bridge should not be used on GFI protected outlets as some outlets will filter out HomePlug power line signal.
- This HomePlug AV Ethernet Bridge should not be used in areas with excessive heat.

- Certain florescent or incandescent lights are noise sources on the electrical and can degrade performance.
- If your building has more than one circuit breaker box, your HomePlug AV Ethernet Bridges may not be able to connect between the different circuit breaker boxes. In this case, connect one HomePlug AV Ethernet Bridge to a power outlet located on each of the circuit boxes. Connect Ethernet cable between each of the HomePlug AV Ethernet Bridges to link the different circuits together. This will allow the HomePlug AV Ethernet Bridges from different circuit breaker boxes to connect.

## Specification

Main Chipset	Qualcomm Atheros AR7400
Computer Interface	IEEE802.3 ; IEEE802.3u ; IEEE802.3ab ; IEEE1901/HomePlug AV
Data PHY Rate	Up to 500Mbps
Standards	HomePlug AV
Network Interface	Four RJ-45 (10/100/1000Base-T Ethernet) One 500Mbps Power Line Port supporting co-existence with HomePlug 1.0 (14/85Mbps)
Security	128-bit AES Link Encryption with Key Management
Frequency Band	2- 50Mhz
Modulation Schemes	OFDM Symbol Modulation on Line synchronization 1024/256/64/16/8—QAM, QPSK, BPSK, ROBO Carrier Modulation

Additional Protocols	Mix of TDMA and CSMA/CA channel access scheme; CO device generates a periodic beacon carrier for channel access scheme
Operation Range	Estimated range of 300 meters in wall power lines
Cabling	Cat. 5 UTP Cable
Operating Temperature	0° C to 40° C ambient temperature
Storage Temperature	-20° C to 70° C ambient temperature
Humidity	10% to 90% maximum (non-condensing)
Power Input	100 ~ 240V @ 50/60Hz Internal
Housing	Plastic (105mm x 76mm x 33mm)
Status Lights	Power: On/Off PLC(power line) Link: Red/Orange/Green/Off Ethernet Link (Port 1 to 4): Solid/Blinking/Off
Certifications	HomePlug AV power line Certification IEEE1901 FCC Class B / CE Mark





