

REV	DESCRIPTION	DRAWN	DATE

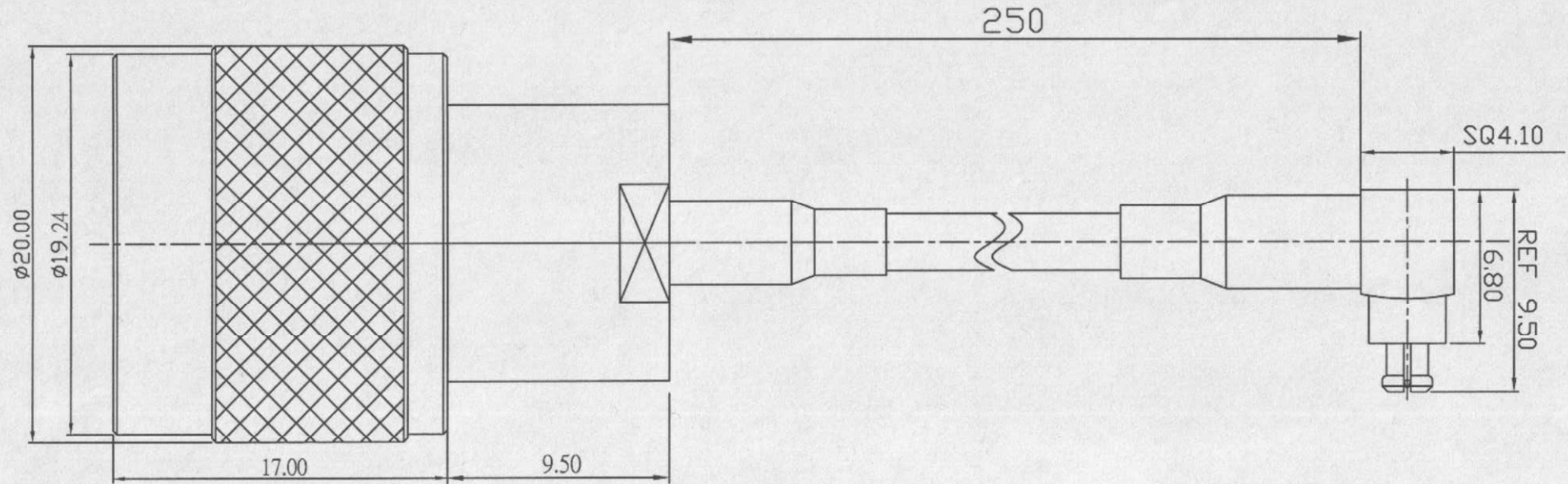

NO	Description	Q'ty	Material	Finish	UNLESS OTHERWISE SPECIFIED	*MAJOR DIMENSION	APPROVED	TITLE	REV
3	MC CARD-2501-3-L-TGN	1	BRASS	GOLD	1.REMOVE ALL BURRS. 2.BREAK ALL CONNERS & EDGES CO.15 MAX. 3.CHAMFER 1ST & LAST THREADS 45°. 4.DIAMETERS ON COMMON CENTERS. TO BE CONCENTRIC WITHIN 0.1 T.I.R. 5.ALL DIMENSIONS ARE AFTER PLATING.	UNLESS OTHERWISE NOTED TOLERANCES 0.5-6=±0.2 6-30=±0.4 30-120=±0.6 120-315=±1.0 ANGLES=±1°	CHECKED	N1158-MC CARD2501	A
2	RG316	1		DRAWN JACKAL			DRAWING NO. 1158231625013-I250		
1	N-1158-2-L-TGN	1	BRASS	NICKEL			DRAWN DATE 07/02/07		
NO	Description	Q'ty	Material	Finish		SCALE 3/1 UNIT MM			